

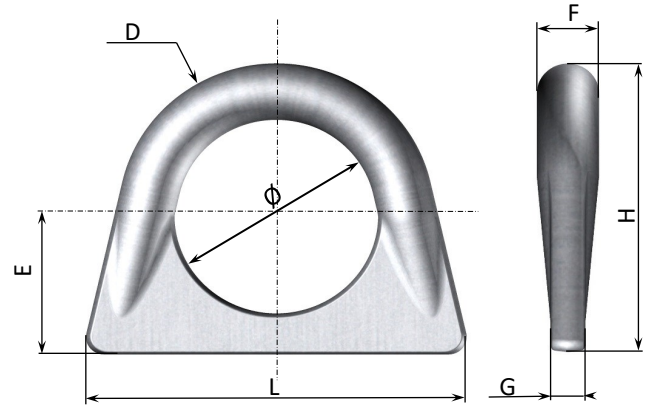

## Caractéristiques techniques

- ◆ Accessoire de levage conforme à la directive européenne machines 2006/42/CE.
- ◆ Acier C25 selon norme NF-EN ISO 683
- ◆ Anneau forgé,
- ◆ Marquage en relief
- ◆ Coefficient de sécurité : 5
- ◆ Notice d'utilisation et de maintenance : NU 16-01
- ◆ Finition grenillée.



Ø	H	L	E	D	F	G	CMU en Kg	Poids en g	Référence
24	43.5	54.5	21.5	21.5	9	5	200	60	22-01-001
31	55	68	27	28	12.5	6.5	500	140	22-01-002
43	67	85.5	32	35	13	6.5	1 000	180	22-01-003
48	82	105	39	43	18	7.5	2 000	400	22-01-004
57	95	128	45	50	21	10	3 000	660	22-01-005
67	107	148	51.5	55.5	25	13.5	4 000	1 020	22-01-006
82	135	189	66	69	28	16	6 000	1 920	22-01-007
100	165	210	84.5	80.5	30	21	8 000	3 120	22-01-008

