



# Anneau (Ecrou) de levage à anse INOX

Ref: 21 – 53

## Caractéristiques techniques



- ◆ Accessoire de levage conforme à la directive européenne machines 2006/42/CE.
- ◆ Acier inoxydable A4 selon norme NF EN 10 088
- ◆ Anneau de qualité classe 8
- ◆ Anneau forgé, usiné
- ◆ Marquage en relief
- ◆ Coefficient de sécurité : 5
- ◆ Notice d'utilisation et de maintenance : NU 14-01
- ◆ Excellente tenue à la corrosion.
- ◆ Finition standard sablée.

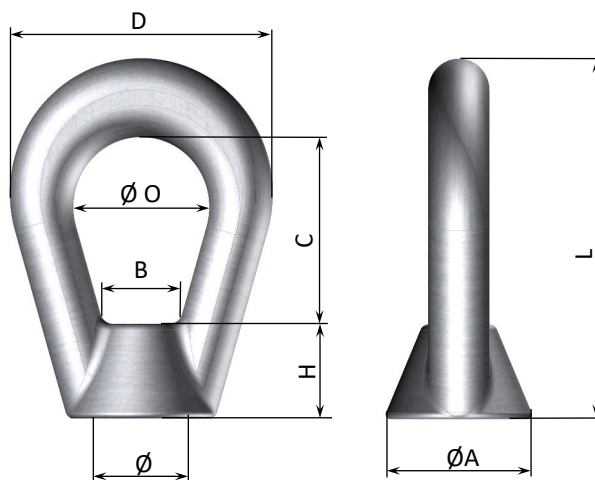

Ø	ØA	L	ØO	D	H	C	B	WLL - CMU en Kg		Poids en g	Référence
								Axial	Traverse at 45°		
M 6	19.5	50	19	37	14	23	12	90	45	60	21-53-006
M 8	19.5	50	19	37	14	23	12	150	75	60	21-53-008
M 10	19.5	50	19	37	14	23	12	250	125	60	21-53-010
M 12	28	73	25	53	19	34	15	700	350	200	21-53-012
M 14	28	73	25	53	19	34	15	700	350	200	21-53-014
M 16	34	82	29.5	60	22	40	16	1 000	500	280	21-53-016
M 18	40	93	34	68	25	45	21	1 400	700	420	21-53-018
M 20	43	100	36	72	26	50	22	1 700	850	500	21-53-020
M 22	47	112	38	76	31	53	26	2 200	1 100	660	21-53-022
M 24	52	121	43	85	35	59	30	2 700	1 350	920	21-53-024
M 27	57	134	45	92	39	63	32	3 500	1 750	1 220	21-53-027
M 30	64	150	48	102	42	72	34	4 500	2 250	1 740	21-53-030

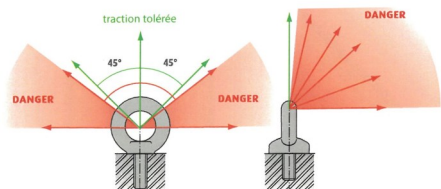

com@colin-milas.com

+33(0)3 24 53 41 91

25, rue du Pavé 08800 LES HAUTES-RIVIERES France

Colin Milas

Levage